

UNTHA

shredding technology

The reliable brand!

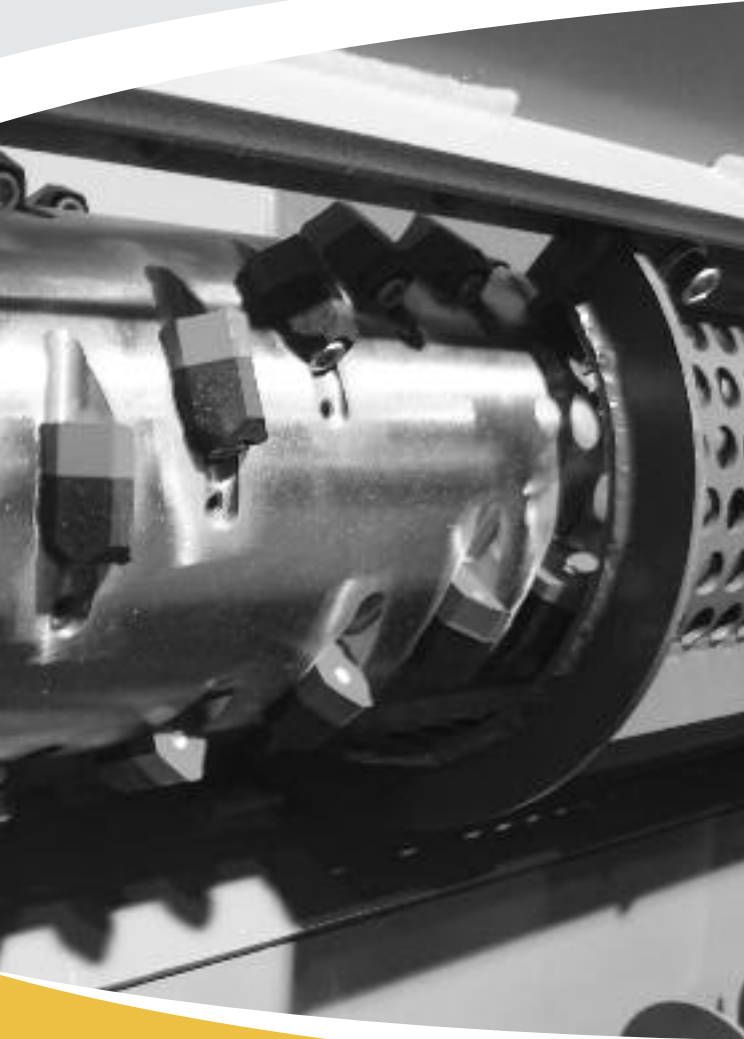

**3-YEARS
NO-WORRIES
WARRANTY!**

SHREDDING SOLUTION FOR WOOD

LR630

LOW PRICE AND HIGH PERFORMANCE

The LR630 is an absolute classic amongst the single-shaft shredders, its excellent cost/performance ratio being one of its most convincing attributes. It is typically used by joiners processing a wood waste volume of 1 to 7 m³ per week.

The homogenous final product is perfectly suited for heat recovery and the production of wood briquettes.

TYPICAL APPLICATIONS

- Solid wood • Chipboard • Veneer (mixed with wood)
- MDF • Cardboard • etc.



LR630

Single-shaft cutting system

TECHNICAL DATA		LR630
Power	kW	11/15/18.5
Hydraulic power	kW	0.75
Rotor Ø	mm	248
Rotor speed	rpm	98
No. of indexable inserts	units	17
Charging hole	mm	624 x 792
Extraction connector Ø	mm	160
Required extraction speed	m/s	28
Weight	kg	ca. 1,300
Noise level pressure LPA1m	dB (A)	82
Perforated screen Ø	mm	15 – 30
Throughput*	cbm	ca. 1 – 2

*) depending on: quality of material and diameter of perforated screen
All dimensions in mm.

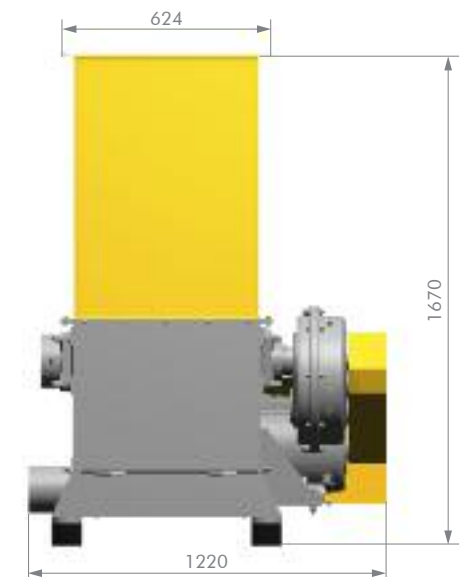
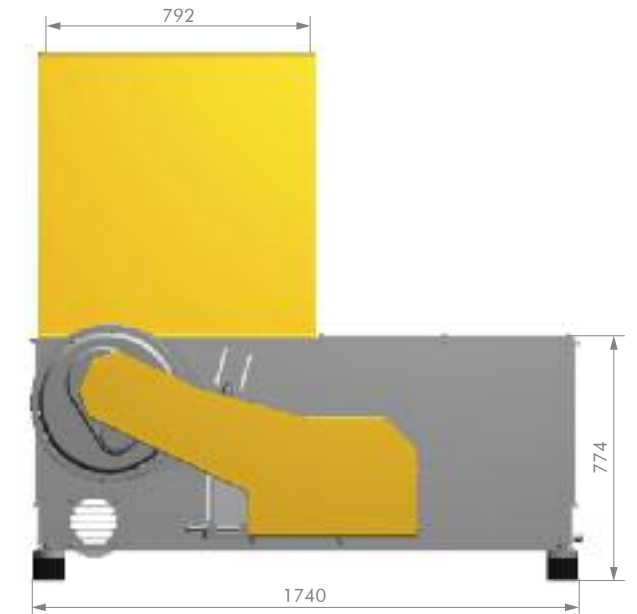

40 years of expertise

More than 8,000 shredders in daily operation!



QUALITY FEATURES

Reliable and economical cutting system

- Replaceable indexable cutters and cutter holders
- Innovative indexable cutter geometry, which enables a pull-through cutting motion – lower power consumption
- Positive fit of indexable cutters and cutter holders
- Precisely defined cutting clearance between indexable cutters and cutting bar

High availability and trouble free operation

- Tried, tested and proven UNTHA LR cutting system
- Highest quality standards in production
- High-quality bearings with an extremely long service life
- Powerful drive concept incl. gearbox damping system
- Reliable hydraulic system

Simple operation and sophisticated control concept

- Automatic foreign material detection and stop
- Automatic reverse function to prevent motor overloading
- Automatic shutoff when idling
- User-friendly operating panel on the control cabinet

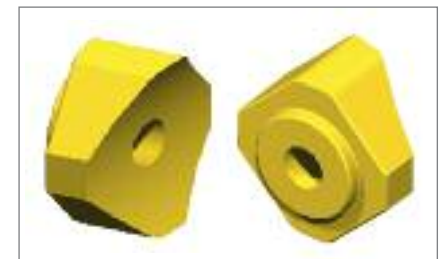

*) or 2,000 h, whichever value occurs first



Options

- Discharge screw conveyors
- Customer-specific hoppers and base frames
- Pipe magnets
- Belt conveyors with magnetic separation

**3-YEARS
NO-WORRIES
WARRANTY!***

UNTHA CUSTOMER SERVICE – AS RELIABLE AS OUR PRODUCTS

Our customers' satisfaction is our number one priority. Our experienced Customer service experts make sure the machines and plant supplied by us are maintained and optimized to increase their service life and ensure efficient and profitable operation.

For more information please refer to our Customer Service brochure.



HOW UNTHA CUSTOMER SERVICE CAN BENEFIT YOU

Cutting systems overhaul

- The low-cost alternative to buying new cutting systems
- Extension of service life and increase in productivity of used cutting systems
- Optimisation of worn cutting systems

Spare parts

- Original UNTHA replacement parts for maximum availability of your machine and plant
- Comprehensive spare parts stock of more than 10,000 items
- Replacement parts are provided within 2 working days thanks to our advanced logistics concept¹⁾
- All original UNTHA replacement parts are "made in Austria"

Repair

- Short response time and expert support in emergencies
- Service hotline
- Highly qualified and experienced service engineers
- General overhauls on site and at the UNTHA Service Centre

Preventive maintenance and maintenance agreements

- UNTHA quality maintenance programmes ensure high up-time of machines
- Regular UNTHA quality maintenance ensures high performance of the machine
- Clear reduction in operating and maintenance costs
- Modular UNTHA quality Maintenance Agreements available

Training

- Expert training courses for optimum operation and maintenance of machines
- Hands-on and multimedia courses for immediate, positive training results
- Individual training courses and on-site advice available

Diagnosis of machine problems

- Prevention of serious damage
- Evaluation by means of state-of-the-art diagnostic equipment
- Remote diagnosis via GSM modem for swift troubleshooting

¹⁾ applies to all articles in stock



OUR MISSION

We have been a reliable and expert partner in the shredding industry for more than 30 years. Based on the latest technologies and with the help of our highly qualified staff, we develop and produce innovative and tailored shredding solutions for all applications.

Our every thought and action revolve around our customers and markets. We provide outstanding products and services of the highest quality and reliability and are therefore able to strengthen our customers' market position.

For us, reliability, credibility and a sound approach to business in both practice and theory are the central values that make our success in international markets possible. These values increase our competitiveness and help us to focus on our core competences and on the ongoing improvement of our business processes. The prerequisites for our success are innovative strength, problem-solving skills and our distinctive quality thinking.



THE FACTS SPEAK IN OUR FAVOUR





shredding technology

The reliable brand!



UNTHA shredding technology

Authorised partner of UNTHA

Moldanstrasse 141
A-5431 Kuchl / Salzburg, Austria
Tel +43 6244 7016 0, Fax +43 6244 7016 1
info@untha.com

www.untha.com